

HB505 & 510 Head Partition Kit

Description

This kit provides all that is required to add a head partition to your Ifor Williams HB505 or HB510 Horsebox trailer.

Tools Required

A pair of 10mm spanners (To pre assemble panel)

Contents:

1	Head Partition panel	Qty: 1
2	Rubber tie (hard)	Qty: 2
3	Rubber tie (soft)	Qty: 2
4	Fixing bolt	Qty: 2
5	Washer	Qty: 4
6	Dome nut	Qty: 2
7	Retainer pin and ring	Qty: 1

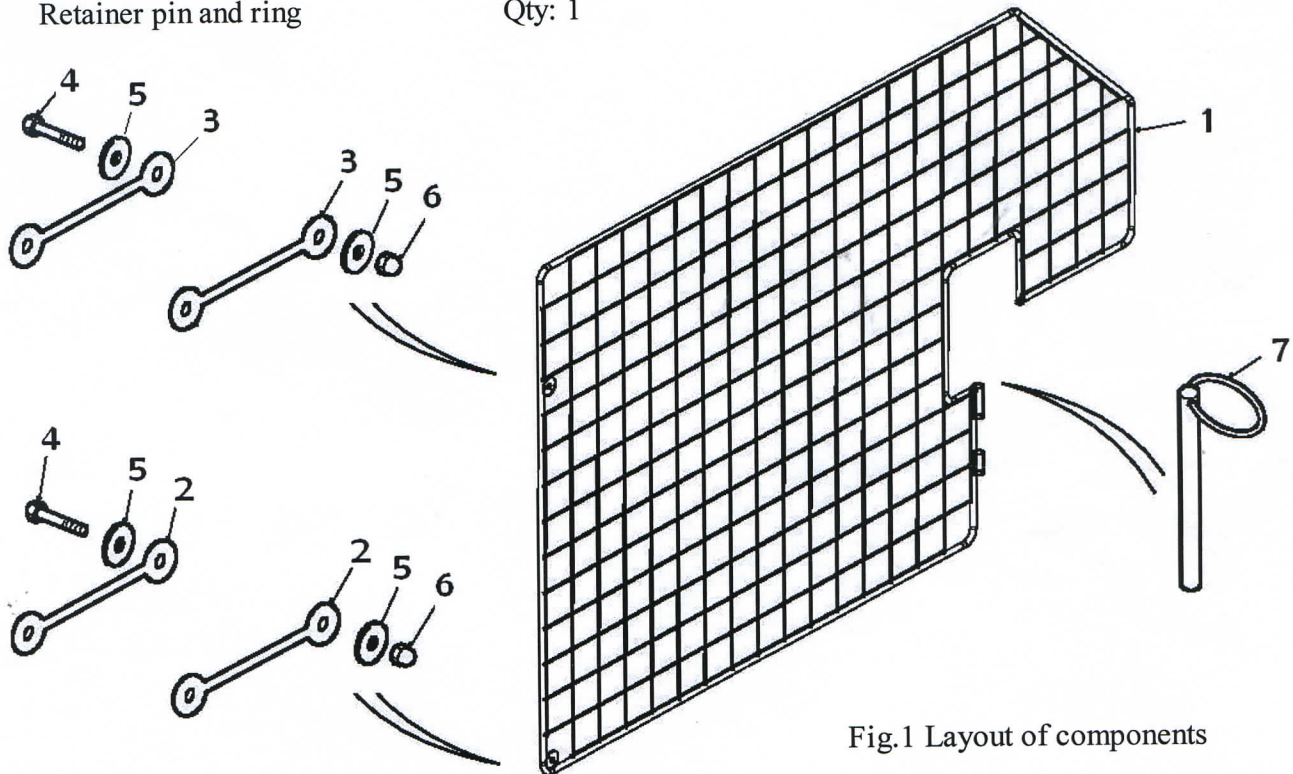

Fig.1 Layout of components

Pre assemble the panel:

1. Firstly identify all the parts and note how they fit onto the mesh panel, particularly that one pair of ties are made from a much softer material and that they are to be fitted only in the upper position.
2. Fix the ties using the Nut, bolt and washer provided, in the sequence shown in Fig.2, noting that the bolt also passes through the pre-fitted washer location in the mesh panel and is to be tightened until it bottoms in the nut and locks.
3. The fixing pin ring should be attached to the pin (Item 7) if this has not already been done.

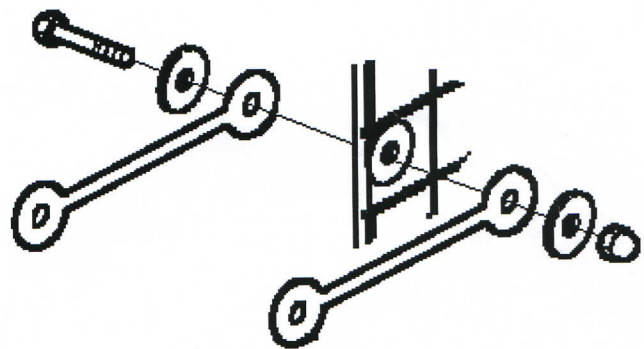

Fig.2 Fitting ties to mesh panel

Fitting panel into the trailer

4. Locate the panel in position on the front partition leaf as shown in Fig. 3, ensure that all three aluminium eye brackets are in line and fix using the retainer pin provided (Item 7).
5. Pull the rubber ties taut and fix in pairs to the hooks on the front frame cross rails, the softer upper ties can be stretched considerably more than the lower ones to enable them to reach the hook.

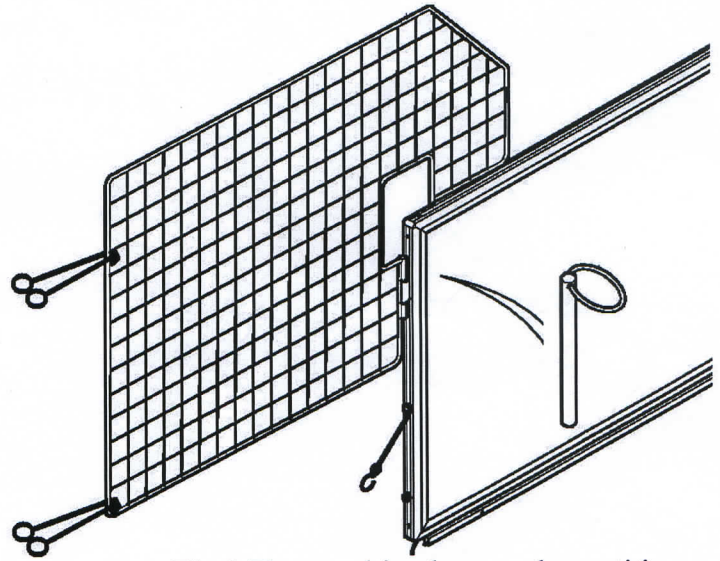
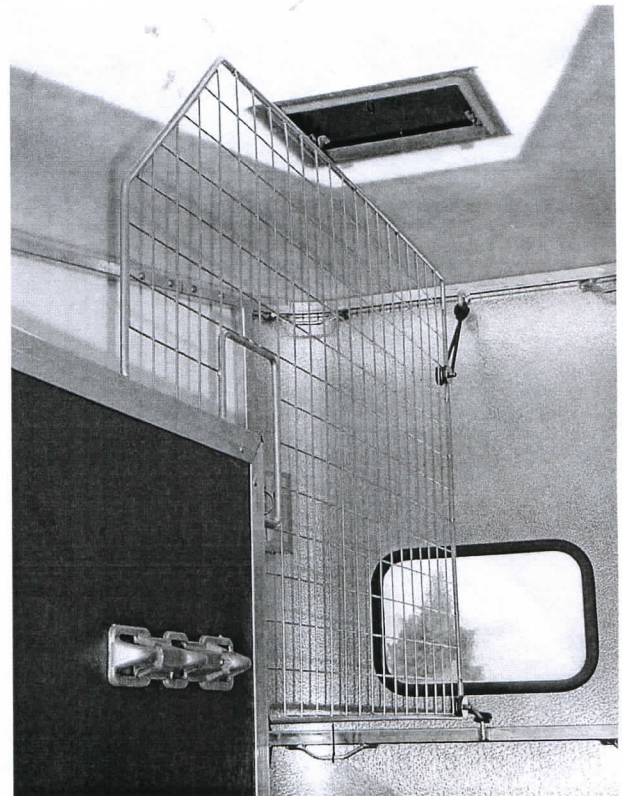

Fig.3 The panel in place on the partition



The finished head partition fitted to a HB505