

# 400Q Stabiliser Fitting Instructions

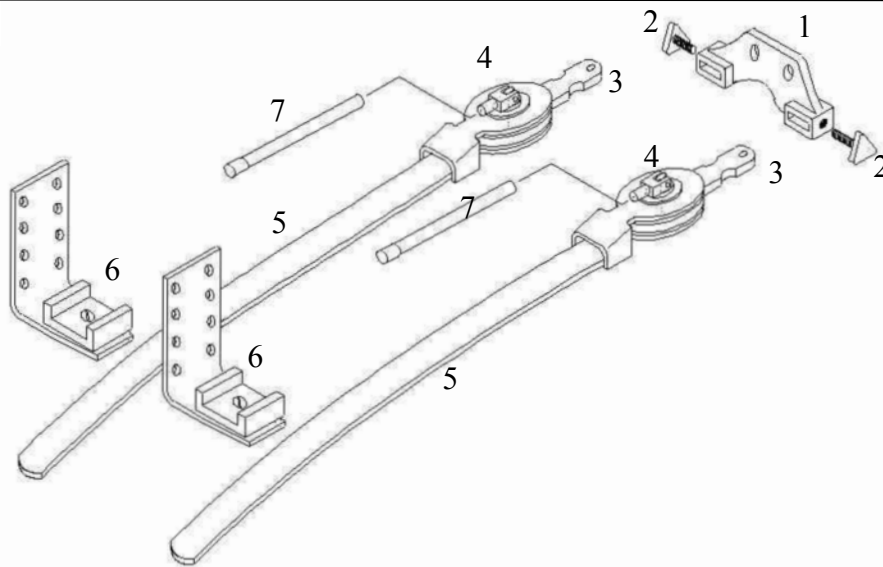

- 1) Twin Car Plate
- 2) Locking Studs and dust caps
- 3) Damper pivot brackets
- 4) Cam lever and 12mm safety type adjusting bolt two lock nuts
- 5) Stabiliser spring arms
- 6) Angle bracket & slipper assemblies
- 7) Tubular handle (detachable)

**To Operate The Quick Release:** To release pressure on the friction discs fit the tubular handle (7) on to cam spigot (4) and lift cam to vertical position. To apply pressure to the friction discs, simply press down until handle is horizontal, remove handle.

## Fitting To The Towing Vehicle

- 1) Remove the towing ball.
- 2) Fit the twin car plate (1) between the towing ball and the car towing bracket (longer high tensile bolts may be necessary).
- 3) Lift the quick release cam (4) and insert damper pivot bracket (3) in to the slot in the twin car plate (1) and secure with locking stud (2). To clear the 'A' frame pull the stabiliser towards you. Repeat for opposite side.

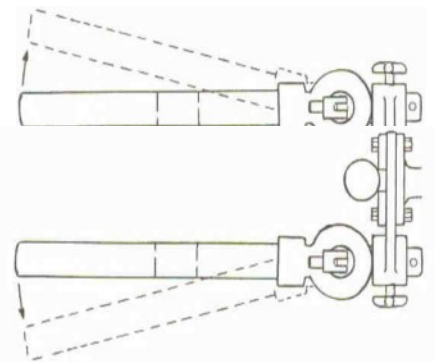
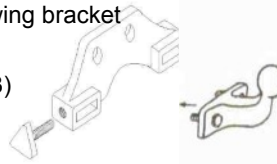

**Fitting To a Caravan With A Fairing:** When fitting the angle bracket (6) to an 'A' frame covered by a plastic fairing it is advisable to remove the fairing and fit directly to the metal frame using saddle clamp brackets available from your dealer. Then replace the fairing over the angle bracket.

## Fitting To a Trailer.

- 1) Load the vehicle and trailer as normal and hitch up in line on a level surface. Please ensure the hitch is fully forward. Then carry out the following to both sides.
- 2) Push the stabiliser spring arm until it is parallel to the trailer 'A' frame.
- 3) Slide the angle bracket and slipper assembly (6) on to the spring arm leaving 5" (120mm) of spring protruding.
- 4) Holding the angle bracket vertical scribe a mark down its edge on to the 'A' frame. Remove the bracket and pull aside the spring arm.
- 5) In the approximate position of the angle bracket on the trailer 'A' frame draw a horizontal centre line equal distance from the top and bottom flanges.
- 6) Position the angle bracket vertical to the lines marked on the 'A' frame and mark through any two horizontal holes on to the centre line. Remove bracket.
- 7) Drill two 8.5mm holes.
- 8) Slide angle bracket assembly back on to spring arm and push to 'A' frame.
- 9) Lock up quick release and lift spring arm at end between 1½" to 2½". Insert the two bolts through the appropriate holes and bolt up with nuts and washers.

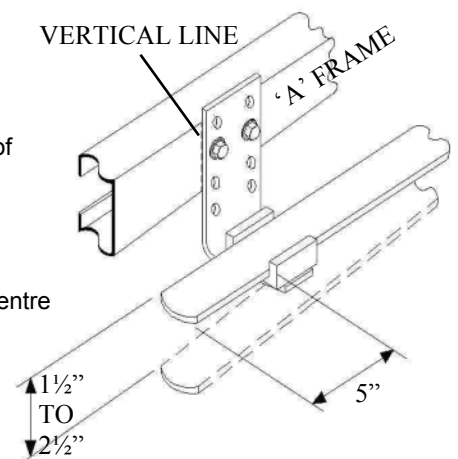

## Adjustments.

- 1) Once fitted check that the springs are completely retained in the plastic slippers and do not catch any part of the caravan or trailer when vehicle is on full lock.
- 2) The stabilisers are factory set but may need adjustment after use.
- 3) To adjust the friction damper assembly you will require the following tools:
  - A set of bathroom scales or suitable spring balance.
  - Two open ended 19mm spanners.

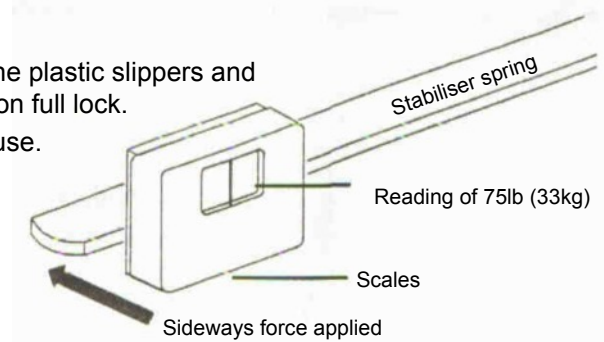

**Note. Adjustment is carried out with quick release locked i.e. pressure applied to friction discs.**

## IMPORTANT!

Please DO NOT use torque wrench as the torque needed on the 12mm adjusting bolt and nut (4) is very small.

- 4) Insert the damper pivot bracket (3) into the slot in the car plate (1) and secure with locking stud(2).
- 5) Apply the scales to the end of the spring arm and push. You are looking for a reading on the scales of approximately 75lbs (33kg). It is emphasised that this is NOT a torque figure but the horizontal push/pull force at the end of the spring arm.
- 6) Adjustment is made by releasing the thin lock nut on the 12mm centre bolt and tightening up the special type lock nut until the appropriate reading is obtained on the scale. Finally, firmly lock up the special nut and thin lock nut together using the two spanners. Take care not to move the special nut on the bolt or you may lose the correct setting. Check tightness of the thin lock nut after 50 miles.
- 7) DO NOT USE ANY OTHER METHOD FOR CHECKING THE STABILISER.

If you have any doubt about servicing your stabiliser please contact your nearest dealer or telephone Bulldog for assistance.

## WARNING!

After fitting and prior to commencing your journey, please check tightness of the locking stud holding the stabiliser into the car bracket. A secondary safety and security feature of the Bulldog stabiliser is the provision of a hole in the end of the damper pivot plate (3). This is to facilitate the use of a padlock (not supplied).

When Boarding Ferries or Off Road on Uneven Ground.

It is advisable to remove stabilisers to avoid damage to the spring arm.

Heavy Trailers.

When reversing very heavy trailers it is recommended that the stabilisers are removed prior to carrying out tight manoeuvres. Failure to do so may result in damage to the stabiliser or car plate.

When Not In Use.

Remove locking stud. Apply grease in the thread car bracket and fit Red Cap. To remove cap just unscrew.

## Bulldog Security Products

Units 1 - 4 Stretton Road, Much Wenlock, Shropshire, TF13 6DH.

Tel: 01952 728171 Fax: 01952 728117

Email sales@bulldogsecure.com www.bulldogsecure.com

